

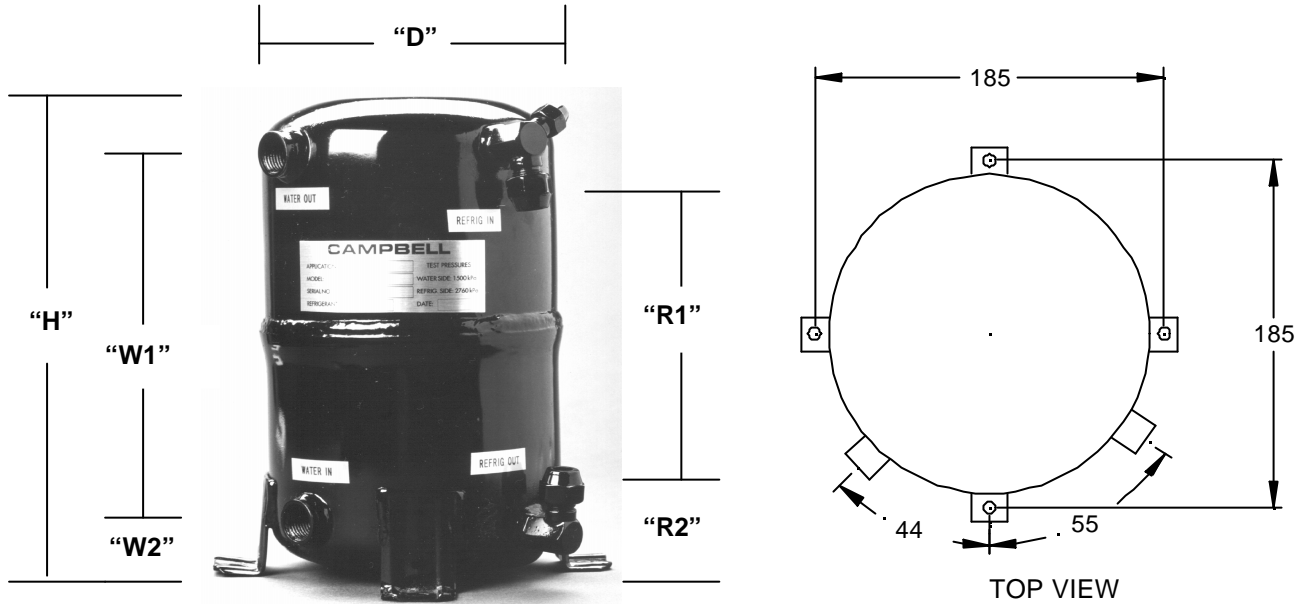

CAMPBELL SHELL & COIL WATER COOLED CONDENSERS. THE “CA” SERIES WATER COOLED CONDENSERS ARE FOR USE WITH SMALL REFRIGERATION OR AIR CONDITIONING SYSTEMS. THEY ARE SUITABLE FOR USE WITH R22 – R404A & R134A REFRIGERANTS.

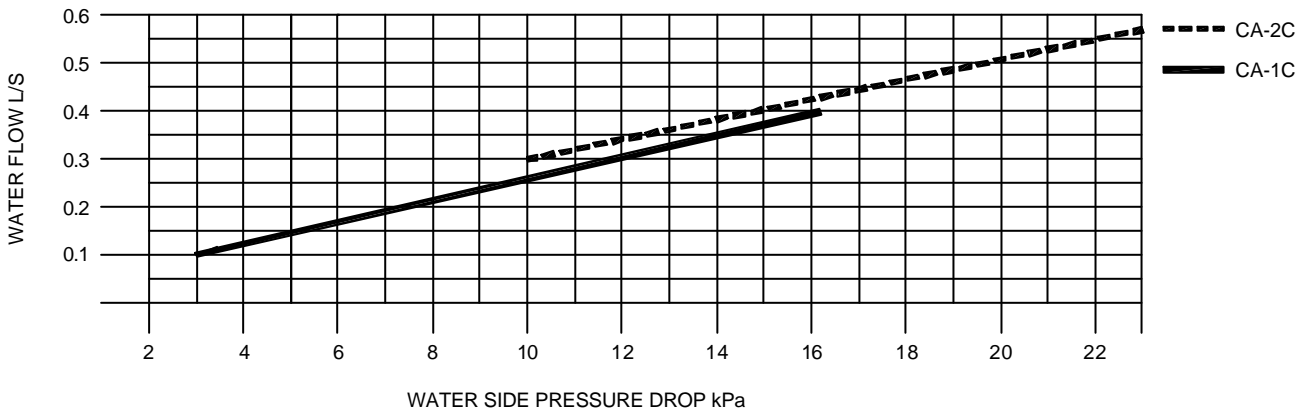

WATER FLOW VS. WATER P.D.



Model	*Nom. Cap. THR (kW)	Water Conns. In / Out	Nominal Water Flow	Refrig. Conns. In / Out	Dimensions						Weight (kg)
					Water		Refrig.		H	D	
					W1	W2	R1	R2			
CA-1C	4.5	1/2" FBSP	0.20 l/s	3/8" Flare	270	155	215	33	170	60	4
CA-2C	8.9	1/2" FBSP	0.39 l/s	3/8" Flare	310	155	245	35	190	65	5

Note: * Nominal capacity based on water entering @ 29.5 °C, leaving 35°C, 43°C condensing temperature.

IN THE INTEREST OF CONTINUOUS PRODUCT IMPROVEMENT SPECIFICATIONS OR PERFORMANCE DATA MAY CHANGE WITHOUT NOTICE.