

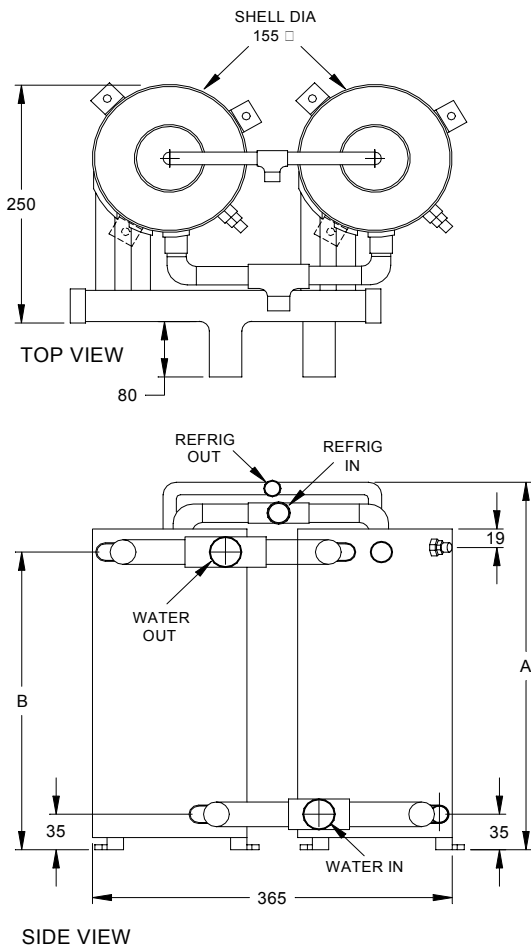

ABN 49 003 452 551

WATER COOLED CONDENSER ASSEMBLIES FOR AIR CONDITIONING OR REFRIGERATION EQUIPMENT. MODELS AVAILABLE FOR FRESH WATER – MARINE SALT WATER – POOL AND SPA WATER HEATERS. CAPACITIES FROM 24 kW TO 60 kW TOTAL HEAT REJECTION. HEAT RECOVERY DISCHARGE GAS DE-SUPERHEATERS.

“S-*R/2” Series



“S-*R/2V Series

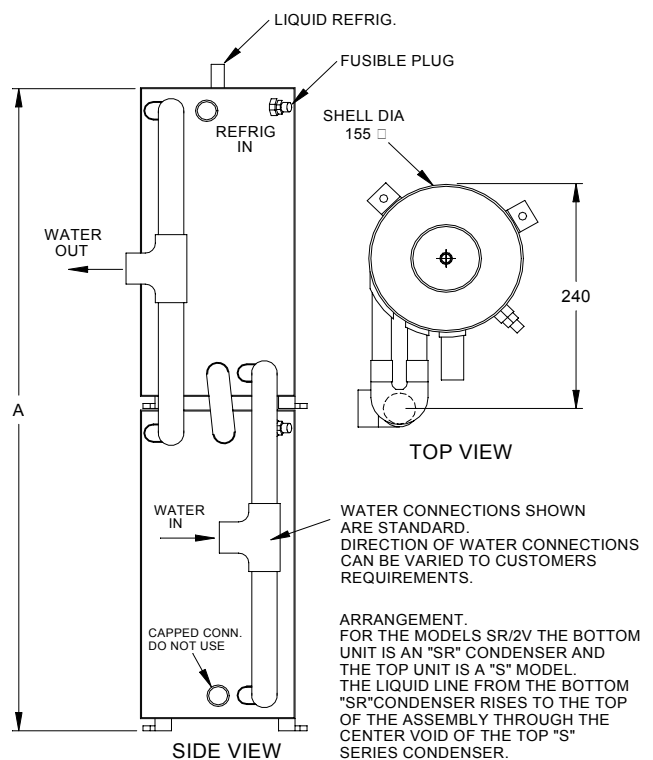

Model Fresh	Refrig. Conns. In / Out	Water Conns. In / Out	Dim. A	Dim. B	Weight kg
S-4R/2H	22mm / 19mm	32mm	294	249	24
S-5R/2H	22mm / 19mm	32mm	330	293	27
S-6R/2H	29mm / 19mm	32mm	398	333	31
S-3R/2V	22mm / 12.5mm	32mm	458	–	20
S-4R/2V	22mm / 12.5mm	32mm	565	–	22
S-5R/2V	22mm / 15mm	32mm	650	–	25
S-6R/2V	22mm / 15mm	32mm	730	–	30

NOTE: Fresh water models all have copper manifolds & fittings.

IN THE INTEREST OF CONTINUOUS PRODUCT IMPROVEMENT SPECIFICATIONS OR PERFORMANCE DATA MAY CHANGE WITHOUT NOTICE.